

RMR

Fresa per Spianatura e Copiatura con 8 Taglienti

- Lavorazione stabile grazie al design esclusivo della fresa
- Risparmio costi grazie all'inserto con 8 taglienti

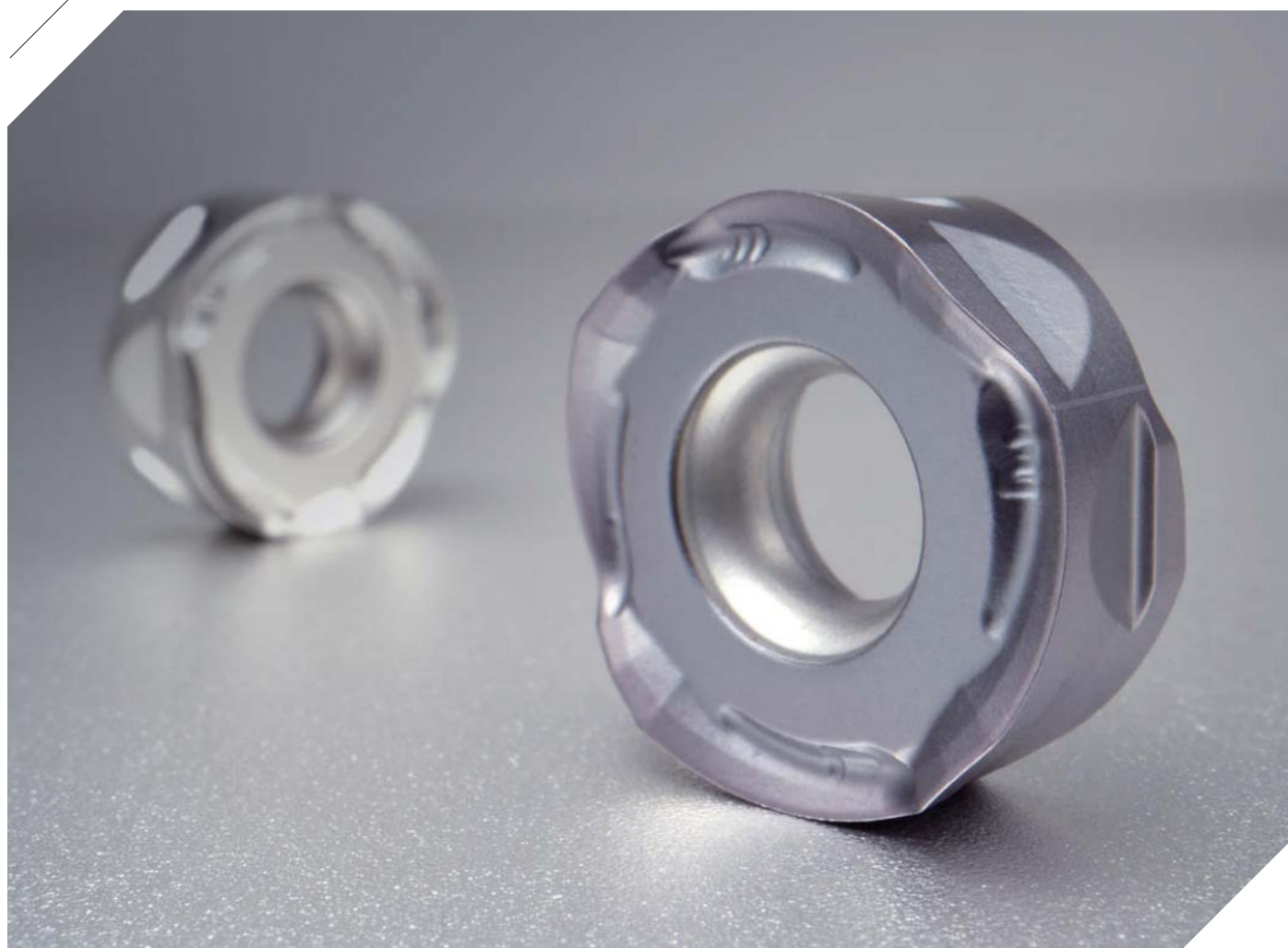

RMR

La nuova RMR Korloy è una fresa per spianatura e copiatura ideata principalmente per i settori stampi e aerospace. L'inserto con 8 taglienti assicura un risparmio dei costi, mentre la speciale struttura antirotazione dà una maggiore stabilità alla fresa riducendo il rischio di rotture e scheggiature impreviste, garantendo una maggiore durata dell'utensile.

Grazie al rompitruciolo compatto e al tagliente a forma di elica, la fresa RMR offre prestazioni di taglio eccellenti anche nelle operazioni di taglio ad alto avanzamento. Il design ottimizzato dell'angolo tra il tratto raschiante e il pezzo in lavorazione garantisce una finitura superficie superiore.

Grazie al design esclusivo e ai vari gradi a disposizione, la fresa RMR dà ottimi risultati nella lavorazione degli stampi. In particolare, in combinazione ai gradi UPC/UNC, offre un'eccellente durata nella lavorazione di materiali tenaci come i componenti aerospaziali, grazie all'applicazione della tecnologia di rivestimento Ultra che ha elevate proprietà di durezza e lubrificazione.

» **Risparmio costi**

- Inserto a 8 taglienti

» **Durata utensile stabile**

- Sistema antirotazione assicura una lavorazione stabile

» **Buona finitura superficie**

- Rompitruciolo compatto

» **Prestazioni ottimizzate**

- Alte prestazioni grazie al rompitruciolo e all'alta elica di spoglia



















Codifica

Manicotto						
RMR	C	M	063	R	- 22 -	5 - RN12
Rich Mill Round	Tipo C: Manicotto	Attacco M: Metrico A: Pollici Nessuno: Asia	Diametro Fresa 050: Ø50 mm	Refrigerante & Direzione R: Con fori, destra NR: Senza fori, sinistra	Diametro interno 22: Ø22 mm	Inserto RN12: RNMX12
N° Inserti 5: 5 taglienti						

Cilindrico						
RMR	S	040	R	- 3	W	32 - 110 - RN12
Rich Mill Round	Tipo S: Cilindrico	Diametro Fresa 040: Ø40 mm	Refrigerante & Direzione R: Con fori, destra NR: Senza fori, sinistra	N° Inserti 3: 3 Taglienti	Tipo di attacco W: Weldon C: Cilindrico	Diametro attacco 32: Ø32 mm
Lunghezza Totale 110: 110 mm						
Inserto RN12: RNMX12						

Gradi e Rompitruccioli Raccomandati

Classifica	Gradi e Rompitruccioli Raccomandati in base ai materiali							
	P		M		K		S	
	C/B	Grado	C/B	Grado	C/B	Grado	C/B	Grado
1° Scelta	 MM	 PC3700	 ML	 PC9540	 MM	 PC6510	 ML	 UNC840
2° Scelta	 MM	 PC5300	 MM	 PC9540	 MM	 PC5300	 ML	 UPC845

Parametri Raccomandati

Materiale				Coppia (N/mm ²)	Durezza Brinell (HB)	Resistenza usura ← Tenacità						ML/MM ap (mm)	
ISO	Materiale	ISO	AISI			Grado	C/B			Grado	C/B		
						PC3700	ML	MM	PC5300	ML	MM		
						vc (m/min)	fz (mm/t)	fz (mm/t)	vc (m/min)	fz (mm/t)	fz (mm/t)		
P	Acciai legati Mn < 1.65	C25	1025	1500	125	100	0.5	0.5	80	0.5	0.5	1 ~ 3	
						180	0.3	0.3	140	0.3	0.3		
		250	0.1	0.1	200	0.1	0.1						
		80	0.5	0.5	80	0.5	0.5						
	C45	1045	1700	190	180	0.3	0.3	140	0.3	0.3			
					250	0.1	0.1	200	0.1	0.1			
	Acciai poco legati ≤ 5%	42CrMo4	4140	1700	175	80	0.5	0.5	80	0.5	0.5		
						160	0.3	0.3	120	0.3	0.3		
Acciai molto legati > 5%	X40CrMoV5-1	D2 H13	1950	200	120	0.7	0.7	100	0.7	0.7			
					140	0.5	0.5	120	0.5	0.5			
					280	0.3	0.3	210	0.3	0.3	1		

Parametri Raccomandati

Materiale				Coppia (N/mm ²)	Durezza Brinell (HB)	Grado	C/B	ML ap (mm)
ISO	Materiale	ISO	AISI			PC9540	ML	
						vc (m/min)	fz (mm/t)	
M	Ferritici/ martensitici	X6CrAl13 X6Cr17	405 430	1800	200	120	0.3	1 ~ 3
						160	0.15	
						200	0.05	
		X12CrS13 X6CrMo17-1	416 434	2850	330	100	0.3	
						140	0.15	
						180	0.05	
	X12Cr13	403 410	2350	330	100	0.3		
					140	0.15		
					180	0.05		
	Austenitici	X5CrNi18-9, X2CrNi18-9 X5CrNiMo17-12-2 XCrNiMo17-12-3	304 316	2000	180	90	0.3	
						120	0.15	
						150	0.05	
Austenitic- ferritici (Duplex)	-	S31803 S32750	2450	260	60	0.3		
					90	0.15		
					120	0.1		

Materiale				Coppia (N/mm ²)	Durezza Brinell (HB)	Resistenza usura ← • → Tenacità						ML/MM ap (mm)		
ISO	Materiale	ISO	AISI			Grado		C/B		Grado			C/B	
						PC6510	ML	MM	PC5300	ML	MM			
						vc (m/min)	fz (mm/t)	fz (mm/t)	vc (m/min)	fz (mm/t)	fz (mm/t)			
K	Ghisa grigia	200	No 30 B	900	180	140	0.25	0.3	120	0.25	0.3	1 ~ 3		
						180	0.2	0.2	160	0.2	0.2			
						230	0.1	0.1	200	0.1	0.1			
	Ghisa sferoidale	500-7	80-55-06	870	155	120	0.25	0.3	110	0.25	0.3			
						160	0.2	0.2	145	0.2	0.2			
						200	0.1	0.1	180	0.1	0.1			

Materiale				Coppia (N/mm ²)	Durezza Brinell (HB)	Resistenza usura ← • → Tenacità				ML ap (mm)
ISO	Materiale	ISO	AISI			Grado		C/B		
						UNC840	ML	UPC845	ML	
						vc (m/min)	fz (mm/t)	vc (m/min)	fz (mm/t)	
S	A base Nickel	15156-3	Inconel625	2650	250	30	0.4	25	0.4	1 ~ 3
						45	0.2	40	0.2	
						60	0.05	55	0.1	
		9723	Inconel718	3000	320	25	0.4	20	0.4	
						40	0.2	35	0.2	
						55	0.05	50	0.1	
	A base cobalto	Stellite	Stellite	3000 ~ 3100	300 ~ 320	30	0.4	20	0.4	
						45	0.2	35	0.2	
						60	0.05	50	0.1	
	A base cobalto	5832-11	Ti-6Al-4V	1400	320	30	0.4	20	0.4	
						50	0.2	40	0.2	
						70	0.05	60	0.1	

Applicazioni

Aerospace (Test di Resistenza all'usura)

Materiale Inconel718

Parametri vc (m/min) = 30, fz (mm/t) = 0.4, ap (mm) = 1.8, con acqua

inserto/Fresa **Inserto** RNMX1204M0E-ML (UNC840) **Fresa** RMRCM050R-22-5-RN12

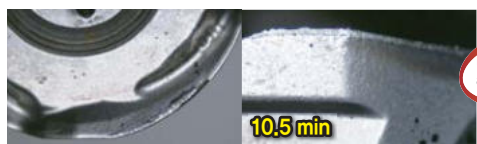

[RMR]

TQ = 264.7 cm³

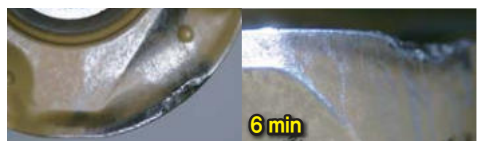

[Competitor]

TQ = 144.4 cm³

Durata più alta del 75%

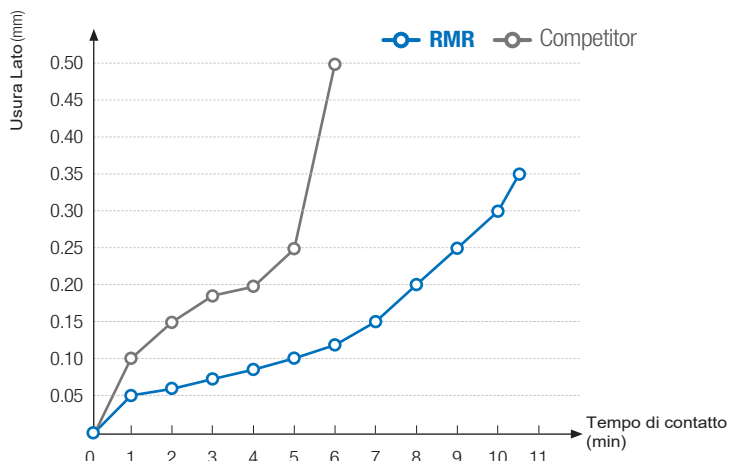

Settore Stampi (Test di Resistenza all'usura)

Materiale Acciaio legato (SCM440, HRC20)

Parametri vc (m/min) = 120, fz (mm/t) = 0.55, ap (mm) = 3, secco

Inserto/fresa **Inserto** RNMX1204M0S-MM (PC3700) **Fresa** RMRCM050R-22-4-RN12



[RMR]



[Competitor]

Durata più alta del 271%

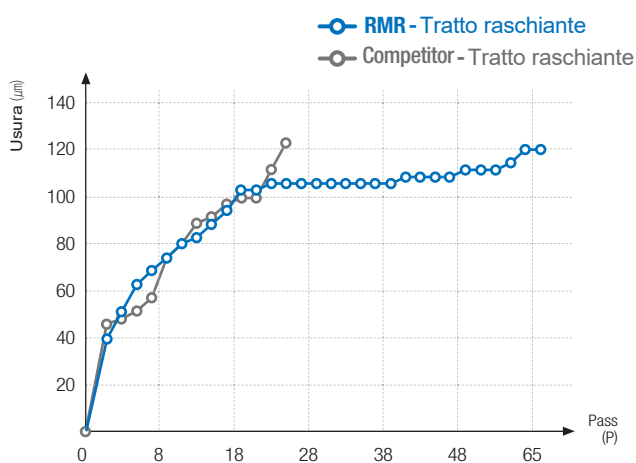

Usura ($vc = 120$ m/min, $fz = 0.55$ mm/t, $ap = 3$ mm)

※ TQ: Totale materiale rimosso (cm³)

Guida alla scelta del corpo fresa

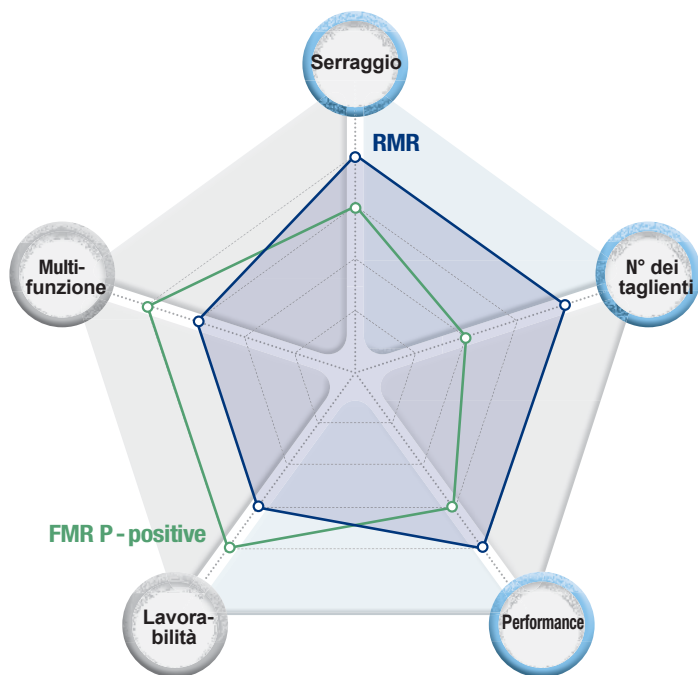

RMR

- Lavorazione stabile grazie al design antirotazione
- Risparmio costi grazie all'inserto con 8 taglienti
- Struttura ottimizzata del tratto raschiante



FMR P - positive

- Fresa multifunzione
- Basso sforzo di taglio



Fresa	Serraggio	N° taglienti	Performance	Lavorabilità	Multifunzionalità
RMR	★★★★	★★★★	★★★★	★★★	★★★
FMR P-positive	★★★	★★	★★★	★★★★	★★★★

Angolo Max Ramping α°

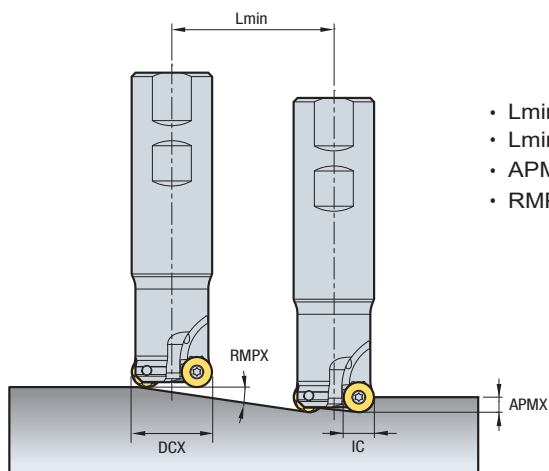



- $L_{min} = APMX / \tan(RMPX)$ (mm)
- L_{min} : Lunghezza minima inclinazione taglio
- APMX : Profondità di taglio
- RMPX : Angolo max. ramping

(mm)

Articolo	Fresa (∅)	Inserto	Diametr. DCX	Angolo Ramping (Max) RMPX	Lunghezza di taglio (Lmin)				
					APMX=1	APMX=1.5	APMX=2	APMX=2.5	APMX=3
RNMX12	32	12	32	1.2	48	72	95	119	143
	40	12	40	1	57	86	115	143	172
	50	12	50	0.8	71	107	143	179	214
	63	12	63	0.64	89	134	179	224	268
	80	12	80	0.52	111	166	221	276	332
	100	12	100	0.42	136	205	273	341	409
	125	12	125	0.34	169	253	338	422	507

Inserto

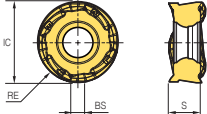
(mm)

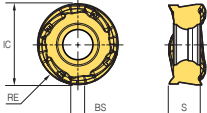
Inserto	Descrizione	Gamma Gradi						IC	BS	RE	S	Geometrie
		PC6510	PC3700	PC5300	PC9540	UNC840	UPC845					
	RNMX 1204M0E-ML	●	●	●	●	●	●	12.0	2.0	6.0	4.75	
	RNMX 1204M0S-MM	●	●	●				12.0	2.0	6.0	4.75	

●: Astock

RMRC(M)-RN12



- AR: -7°
- RR: -13°

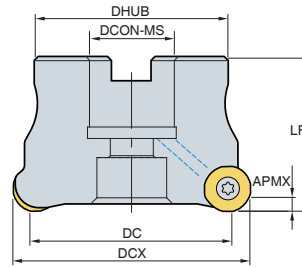

(mm)

Codice	Stock		DCX	DC	APMX	DHUB	DCON-MS	LF		MIID
RMRCM 050R-22-5-RN12	●	5	50	40.4	3.5	42	22	40	0.28	RNMX12
050R-22-6-RN12	●	6	50	40.4	3.5	42	22	40	0.29	
063R-22-6-RN12	●	6	63	53.4	3.5	42	22	40	0.45	
063R-22-7-RN12	●	7	63	53.4	3.5	42	22	40	0.46	
080R-27-6-RN12	●	6	80	70.4	3.5	60	27	50	0.83	
080R-27-8-RN12	●	8	80	70.4	3.5	60	27	50	0.82	
100R-32-7-RN12	●	7	100	90.4	3.5	70	32	63	1.67	
100R-32-9-RN12	●	9	100	90.4	3.5	70	32	63	1.67	
125R-40-10-RN12	●	10	125	115.4	3.5	90	40	63	2.82	
125R-40-12-RN12	●	12	125	115.4	3.5	90	40	63	2.83	
RMRC 080R-25.4-6-RN12	●	6	80	70.4	3.5	60	25.4	50	0.85	
080R-25.4-8-RN12	●	8	80	70.4	3.5	60	25.4	50	0.85	
100R-31.75-7-RN12	●	7	100	90.4	3.5	70	31.75	63	1.71	
100R-31.75-9-RN12	●	9	100	90.4	3.5	70	31.75	63	1.71	
125R-38.1-10-RN12	●	10	125	115.4	3.5	90	38.1	63	2.88	
125R-38.1-12-RN12	●	12	125	115.4	3.5	90	38.1	63	2.88	

●: Stock item

» Inerti disponibili



RNMX-ML



RNMX-MM

Codice	Rivestimento					
	PC6510	PC3700	PC5300	PC9540	UNC840	UPC845
RNMX 1204M0E-ML				●	●	●
1204M0S-MM	●	●	●			

●: Stock item

» Attacchi disponibili

Codice	DCON-MS	Attacco NC
RMRCM 050R-22-□-RN12	22	BT□□-FMC22-□□
063R-22-□-RN12		
080R-27-□-RN12	27	BT□□-FMC27-□□
100R-32-□-RN12	32	BT□□-FMC32-□□
125R-40-□-RN12	40	BT□□-FMC40-□□

Codice	DCON-MS	Attacco NC
RMRC 080R-25.4-□-RN12	25.4	BT□□-FMC25.4-□□
100R-31.75-□-RN12	31.75	BT□□-FMC31.75-□□
125R-38.1-□-RN12	38.1	BT□□-FMC38.1-□□

» Ricambi

Specifiche	Vite	Chiave
Ø50 ~ Ø125	FTNA0411-A	TW15S

RMRS-RN12



- AR: -7°
- RR: -15° ~ -13°

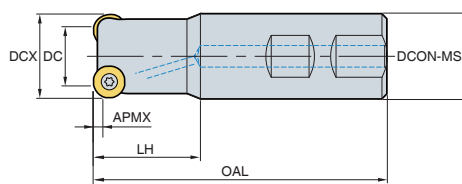

(mm)

	Codice	Stock		DCX	DC	APMX	OAL	LH	DCON-MS	Shank		MIID	
RMRS	032R-2W32-110-RN12	●	2	32	22.4	3.5	110	40	32	W	0.56	RNMX12	
	032R-3W32-110-RN12	●	3	32	22.4	3.5	110	40	32	W	0.55		
	032R-2C32-200-RN12	●	2	32	22.4	3.5	200	40	32	C	1.09		
	032R-3C32-200-RN12	●	3	32	22.4	3.5	200	40	32	C	1.09		
	040R-3W32-110-RN12	●	3	40	30.4	3.5	110	40	32	W	0.62		
	040R-4W32-110-RN12	●	4	40	30.4	3.5	110	40	32	W	0.62		
	040R-3C32-200-RN12	●	3	40	30.4	3.5	200	40	32	C	1.15		
	040R-4C32-200-RN12	●	4	40	30.4	3.5	200	40	32	C	1.15		
	050R-5W40-120-RN12			5	50	40.4	3.5	120	40	40	W		1.08
	050R-6W40-120-RN12			6	50	40.4	3.5	120	40	40	W		1.08
	050R-5C42-300-RN12			5	50	40.4	3.5	300	40	42	C		3.05
	050R-6C42-300-RN12			6	50	40.4	3.5	300	40	42	C		3.05
	063R-6W40-130-RN12			6	63	53.4	3.5	130	50	40	W		1.43
	063R-7W40-130-RN12			7	63	53.4	3.5	130	50	40	W		1.43
	063R-6C42-300-RN12			6	63	53.4	3.5	300	50	42	C		3.3
	063R-7C42-300-RN12			7	63	53.4	3.5	300	50	42	C		3.26

●: Stock item

» Inerti disponibili



RNMX-ML



RNMX-MM

Codice	Rivestimento					
	PC6510	PC3700	PC5300	PC9540	UNC840	UPC845
RNMX 1204M0E-ML				●	●	●
1204M0S-MM	●	●	●			

●: Stock item

» Ricambi

Specifiche	Vite 	Chiave
Ø32 ~ Ø63	FTNA0411-A	TW15S

The logo consists of a stylized 'P' and 'C' in black with a blue gradient, followed by the word 'PALEARICARLO' in a bold, black, sans-serif font.

PALEARICARLO



Via Asmara, 7
21052 Busto Arsizio - Italia
T+39 0331 350 000
ordini@palearicarlo.com
www.palearicarlo.com